



HERGESTELLT  
MIT ÖKOSTROM

 Heckert Solar



## NEMO® 4.2 80 M

### MONOKRISTALLINES PV-MODUL

**Made in Germany** . Alle NeMo® Module werden mit modernster Technologie ausschließlich in Deutschland an den beiden Produktionsstandorten in Chemnitz oder im thüringischen Langenwetzendorf gefertigt.

**Leistungsstabilität** . innovatives thermisches Laserstrahl-separieren mittels microCELL™ MCS erhält mechanische Festigkeit der Zellen

**Nachhaltig** . Unsere NeMo® Module werden mit Strom aus den eigenen PV-Anlagen und zugekauftem Ökostrom hergestellt.

### MONOCRYSTALLINE PV-MODULE

**Made in Germany** . All NeMo® modules are manufactured with the latest production technology exclusively in Germany at our production sites in Chemnitz and Langenwetzendorf.

**Performance stability** . innovative thermal laser separation microCELL™ TLS preserves mechanical strength of the cells

**Sustainable** . Our NeMo® modules are manufactured with electricity from our own PV plants and additionally acquired green electricity.

WWW.HECKERT-SOLAR.COM



**Jahre**  
Solarmodule  
Made in Germany

LEISTUNGSKLASSEN | POWER CLASSES

395

400

405

Nennleistung P <sub>MPP</sub>	Rated Power P <sub>MPP</sub>	Wp		395	400	405
Modulwirkungsgrad STC	Efficiency of the Module STC	%		20,3	20,5	20,8
Kurzschlussstrom I <sub>SC</sub>	Short circuit current I <sub>SC</sub>	A	STC	8,90	8,96	9,06
Strom bei Maximalleistung I <sub>MPP</sub>	Current at maximum load I <sub>MPP</sub>	A	STC	8,36	8,45	8,60
Leerlaufspannung U <sub>OC</sub>	Open circuit voltage U <sub>OC</sub>	V	STC	55,47	55,27	55,05
Spannung bei Maximalleistung U <sub>MPP</sub>	Voltage at maximum load U <sub>MPP</sub>	V	STC	47,64	47,59	47,44
Maximale Systemspannung VDC	Maximum System Voltage VDC	V			1000	
Rückwärtsbestromung I <sub>R</sub>	Reverse current feed I <sub>R</sub>	A			32,0	
Temperaturkoeffizient I <sub>SC</sub>	Temperature coefficient I <sub>SC</sub>	% K			0,037	
Temperaturkoeffizient U <sub>OC</sub>	Temperature coefficient U <sub>OC</sub>	% K			-0,263	
Leistungskoeffizient P <sub>MPP</sub>	Performance coefficient P <sub>MPP</sub>	% K			-0,34	
Zertifizierte Schneelast *	Certified Snow Load *	Pa		Front: Designload 5400 Pa, Testload 8100 Pa Back: Designload 1600 Pa, Testload 2400 Pa		
VDE Zertifikate	VDE Certificate			IEC 61215 (Bauartegnung/Design qualification) IEC 61730 (Sicherheitsqualifizierung/Safety qualification)		
VDE Zertifikate Zusatz	VDE Certificates additional			IEC 61701 (Salznebelkorrosion/Salt Mist Corrosion) IEC 62716 (Ammoniak-Korrosion/Ammonia Corrosion)		
Produktgarantie	product warranty			15 Jahre / 15 years		

WEITERE DATEN | FURTHER DATA

Zellen	Cells	80 monokristalline G12 Zellen im Halbzellendesign, 12 Busbar 80 monocrystalline G12 half cut cells, 12 busbar
Glas	Glass	3,2 mm hochtransparentes, antireflexbeschichtetes ESG-Glas 3,2 mm highly transparent, ESG-glass with anti-reflective coating
Rahmen	Frame	35 mm silber eloxierter Aluminiumrahmen 35 mm silver anodized aluminium frame
Solarbox	Solar box	PV-GZX312 Solarbox Schutzklasse IP 68 (Nichtbrennbarkeitsstufe 5 VA), 4 Bypass-Dioden PV-GZX312 Junction Box protection class IP 68 (fl ammability level 5 VA), 4 bypass diodes
Anschlusskabel	Connecting Cable	4 mm² Stäubli MC4 Stecker +/-, IP 68, Kabellänge: 2 x 160 cm 4 mm² Stäubli MC4 connector +/-, IP 68, cable length: 2 x 160 cm

Maximal garantierte Toleranz	Maximum guaranteed tolerance	0/+4,99 Wp
25 Jahre Leistungsgewährleistung	25 years performance warranty	10 Jahre 90 %, 25 Jahre 80 % 10 years 90 %, 25 years 80 %
Modulabmessungen H x B x T	Dimensions of the Module H x W x D	1736 x 1122 x 35 mm
Modulgewicht	Weight of the Module	21 kg
WEEE-Reg.-Nr.	WEEE-Reg.-No.	DE 42676826

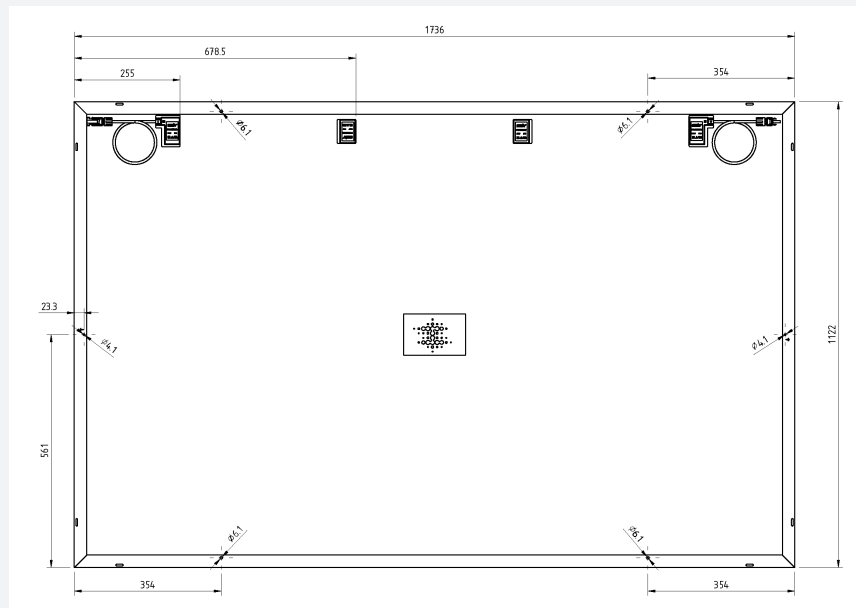

Design optimized with  
 SmartCalc.Module  
[www.cell-to-module.com](http://www.cell-to-module.com)

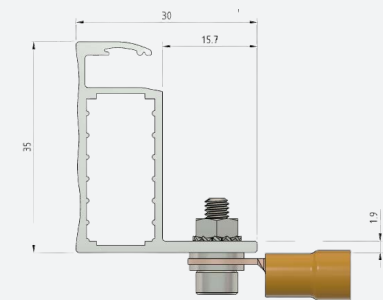

Standard Testbedingungen STC: Einstrahlung 1.000 W / m<sup>2</sup> mit Spektrum AM 1,5 bei einer Zelltemperatur von 25 °C. Maximale Wirkungsgradreduktion bei 200 W / m<sup>2</sup>: 2 % . NMOT- Wert : Nominal Module Operating Temperature = Nennbetriebs - Modultemperatur bei einer Bestrahlungsstärke von 800W / m<sup>2</sup> und einer Umgebungstemperatur von 20 °C. Zulässige Betriebstemperatur zwischen - 40 °C bis + 85 °C. Abmaße +/- 3 mm. Nennleistung Messtoleranzen: PMPP +/- 4 %, UOC / ISC +/- 10 %. Technische Änderungen vorbehalten. Alle Angaben ohne Gewähr. Design Load = Bemessungs-last, Testload = Prüflast. Bitte beachten Sie unsere Installationsanleitung.

Standard Test Conditions STC: Irradiation 1,000 W / m<sup>2</sup> with a spectrum of AM 1.5 at a cell temperature of 25 °C. Maximum reduction in efficiency at 200 W / m<sup>2</sup>: 2 % . NMOT-Data: Nominal Module Operating Temperature at irradiation 800 W / m<sup>2</sup> and an ambient temperature of 20 °C. Operating temperature range between - 40 °C and + 85 °C. All dimensions: +/- 3 mm. Measurement tolerances: PMPP +/- 4 %, UOC / ISC +/- 10 %. Subject to technical alternations. No liability is assumed for particulars. Please follow our installation instructions.